

Operating Instructions

Cassette Auto Changer

Model AG-**CL52**_P

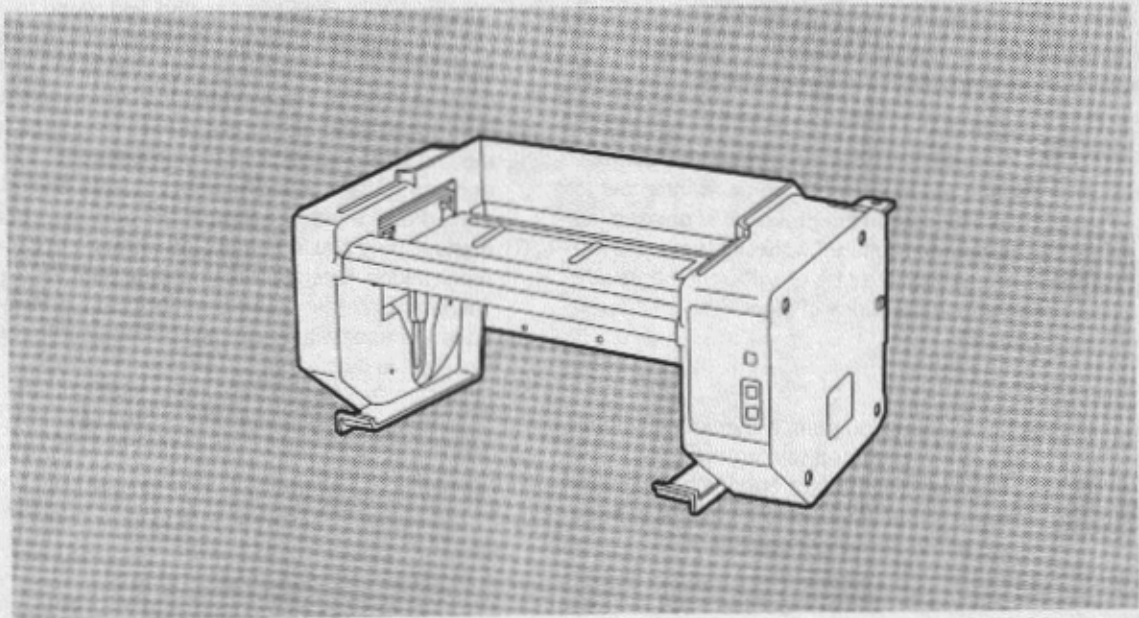

Panasonic[®]

Before attempting to connect, operate or adjust this product, please read these instructions completely.

Table of Contents

AG-RT600A settings	3
Installing the AG-CL52 onto AG-RT600A	3
Controls and operation	6
Specifications	7

Safety Information

CAUTION:
INSTALLATION OF THE CASSETTE AUTO CHANGER MUST BE CARRIED OUT BY AUTHORIZED SERVICE PERSONNEL.

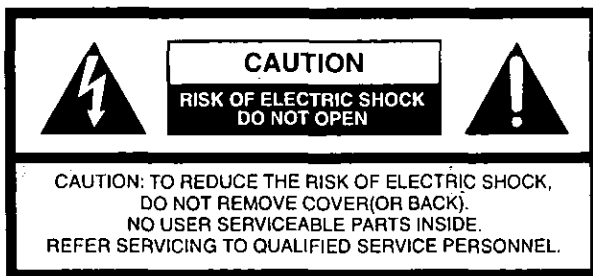

The lightning flash with arrowhead symbol, within an equilateral triangle, is intended to alert the user to the presence of uninsulated "dangerous voltage" within the product's enclosure that may be of sufficient magnitude to constitute a risk of electric shock to persons.



The exclamation point within an equilateral triangle is intended to alert the user to the presence of important operating and maintenance (service) instructions in the literature accompanying the appliance.

WARNING:
TO REDUCE THE RISK OF FIRE OR SHOCK HAZARD, DO NOT EXPOSE THIS EQUIPMENT TO RAIN OR MOISTURE.

FCC Note:

This device complies with Part 15 of the FCC Rules. To assure continued compliance follow the attached installation instructions and do not make any unauthorized modifications.

This equipment has been tested and found to comply with the limits for a class A digital device, pursuant to Part 15 of the FCC Rules. These limits are designed to provide reasonable protection against harmful interference when the equipment is operated in a commercial environment. This equipment generates, uses, and can radiate radio frequency energy and, if not installed and used in accordance with the instruction manual, may cause harmful interference to radio communications. Operation of this equipment in a residential area is likely to cause harmful interference in which case the user will be required to correct the interference at his own expense.

CAUTION:
TO REDUCE THE RISK OF FIRE OR SHOCK HAZARD AND ANNOYING INTERFERENCE, USE THE RECOMMENDED ACCESSORIES ONLY.

AG-RT600A settings

First, proceed with the AG-RT600A settings.

- 1) Set the recording time mode.
- 2) Set TAPE IN and TAPE END on menu page 3 to REC and STOP, respectively.
(Both settings were set to STOP at the factory.)
As a result, the VTR will be automatically set to recording mode when the tape is inserted from this unit.
When the TAPE IN setting is changed from REW to EJECT, and the tape is inserted from this unit, the VTR will automatically rewind the tape to the start and set itself to the recording mode.
When the TAPE IN setting is left unchanged at STOP, the VTR will remain in the stop mode even when the tape is inserted from this unit.
In this case, recording can be started using the AG-A11 which is available as an optional accessory.

Installing the AG-CL52 onto AG-RT600A

1. Remove the top, side and front panels of AG-RT600A.

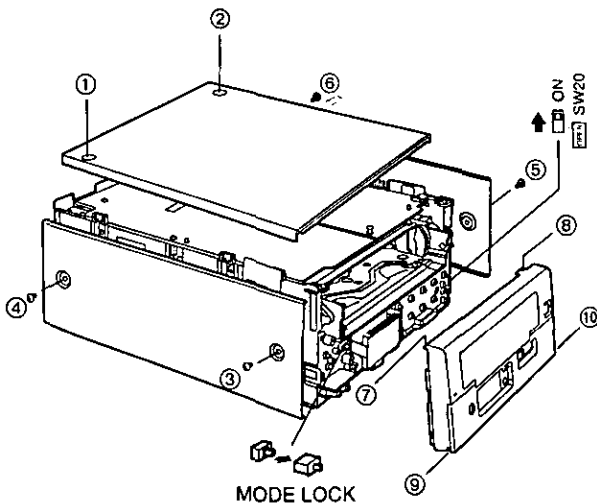

- 1) Remove the Top Panel by unscrewing the two screws ① and ②.
- 2) Remove the Side Panel by unscrewing the four screws ③, ④, ⑤ and ⑥.
- 3) Remove the Front Panel by unscrewing the two screws ⑦, and ⑧ and releasing tabs ⑨ and ⑩.
- 4) Remove the MENU/REC LOCK (MODE LOCK) switch knob, and set the switch to the OFF (center) position.
- 5) Set SW6520 (SW20) to ON.
(The tape will be automatically ejected when it reaches the end during recording.)

2. Open the top circuit board of AG-RT600A.

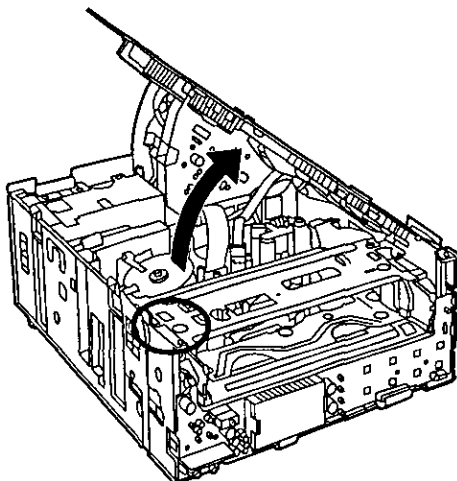

Installing the AG-CL52 onto AG-RT600A

3. Push the accessory catch into the hole.
(The catch is now bent.)

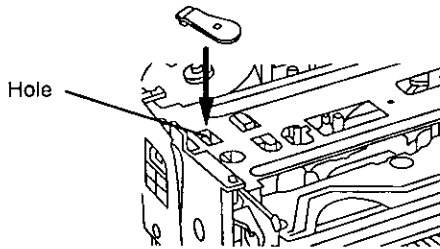

4. While the catch is held down in position, rotate it counterclockwise by about 30 degrees.

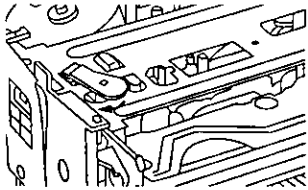

5. While the catch is still held down in position, shift it toward the back of the VTR so that it fits into the hole.

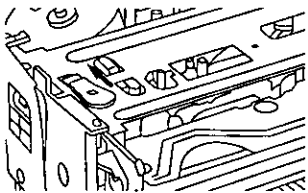

6. Remove the front feet of AG-RT600A.

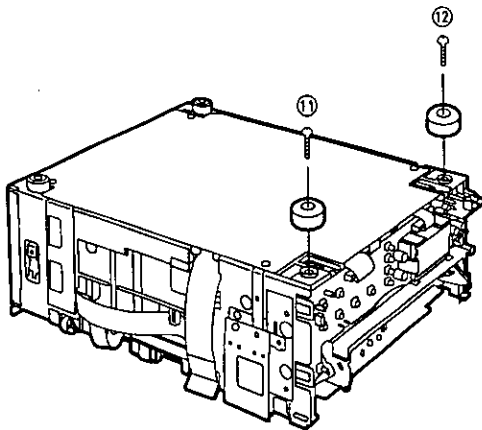

1) Remove the two front feet by unscrewing the two screws
⑪ and ⑫.

Installing the AG-CL52 onto AG-RT600A

7. Attach the cassette auto changer mounting bracket to AG-RT600A.

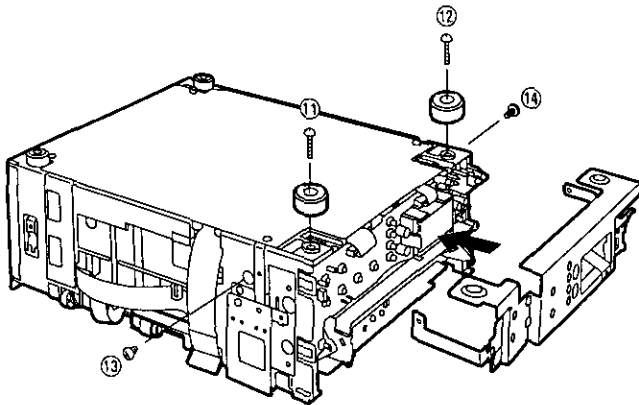

- 1) Attach the cassette auto changer mounting bracket to the front of AG-RT600A and secure it using two screws supplied ⑬ and ⑭, and screws ① and ②.

8. Secure side panel and connect the cable.

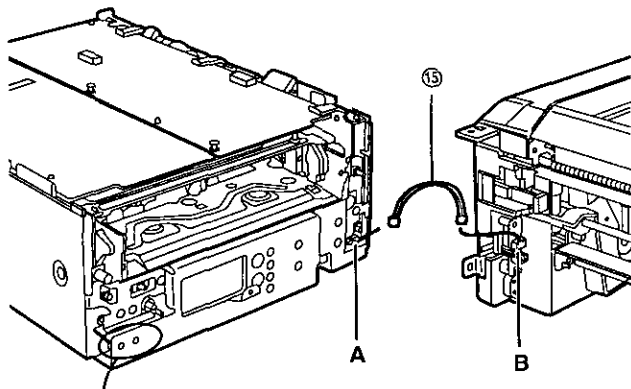

- 1) Secure side panels using screws ③, ④, ⑤ and ⑥. (See page 3.)
- 2) Connect the cable ⑮ to Connector A located at the front of the printed circuit board of the AG-RT600A.
- 3) Connect other end of the supplied cable ⑮ to the Connector B of the cassette auto changer.

Note:

When connecting the cable ⑮ and installing the changer, take care not to sandwich the cable ⑮.

Make sure that the microphone jack and remote connector are firmly connected with the AG-CL52.

9. Fix the cassette auto changer and secure the top panel.

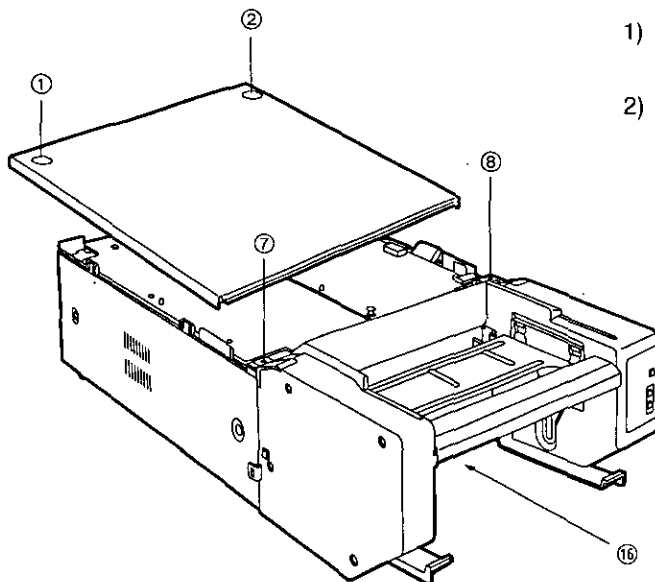

- 1) Secure the cassette auto changer to AG-RT600A using screws ⑦ and ⑧, and supplied screw ⑯.
- 2) Secure the top panel using screws ① and ②.

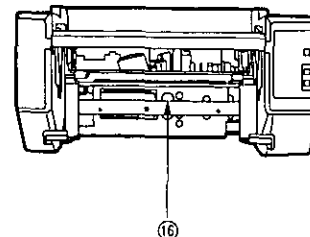

Controls and operation

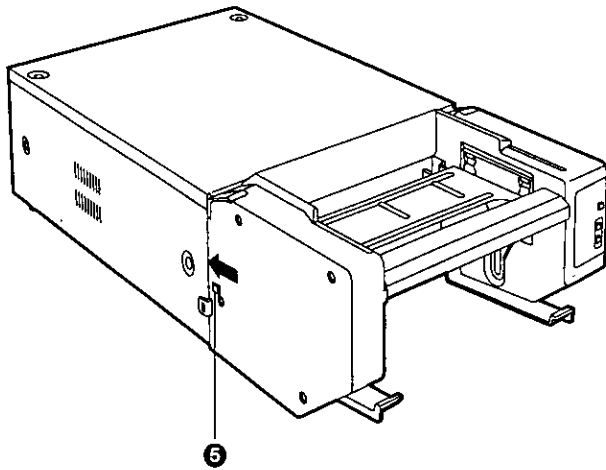
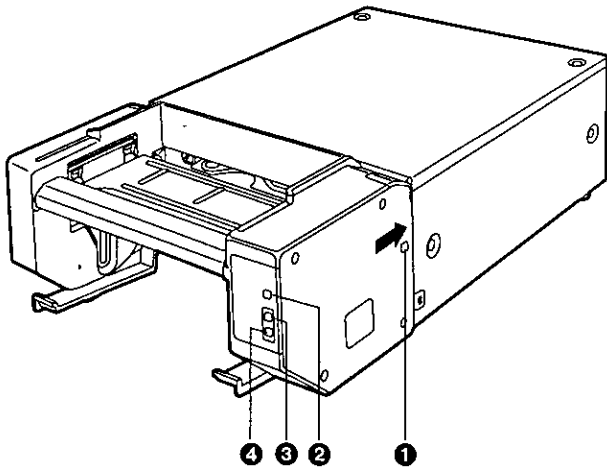

- 1 Eject switch**
Turn this switch to eject the cassette tape.
- 2 Rec lamp/warning lamp**
This lamp lights when the recording is in progress. It flashes to signal that the cassette tape is caught on something in the unit or to indicate some other trouble.
- 3 Start button**
Press this button to load the cassette tape onto the VTR.
- 4 Reset button**
Press this button to reset the AG-CL52 operation when the error has occurred.
- 5 VTR Power switch**
Turn this switch when the power is turned ON.
- 6 Remote connector (VTR side)**
Connect the optional remote controller AG-A11. Operation such as recording, playback, fast forwarding/rewinding and stop is enabled only when the remote controller is operated.

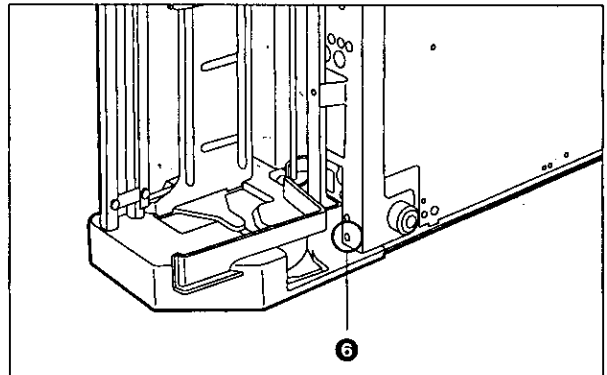

Operation method

- 1) When two cassette tapes which have been rewound to the start are placed on the unit and the start button 3 is pressed, the cassette tape at the bottom level is inserted into the VTR, and the REC lamp 2 lights.
- 2) The third cassette tape is placed on top of the second tape.
- 3) When the first tape is recorded to its end, it is automatically ejected, and the second tape is automatically inserted into the VTR, after which recording is commenced.

Note:

The tape which has been ejected to the unit's bottom level must be removed before the third tape is ejected.

Specifications

Power supply:	12 V (supplied from VTR)
Power consumption:	0.42 A

Recommended
cassette tapes: VHS cassette tape
Up to two cassettes can be
installed in the unit.

Applicable VTR: AG-RT600A

Operating temperature: 41°F to 104°F (5°C to 40°C)

Operating humidity: 35% to 80%

Dimensions: 16 ⁷/₈" (W) × 5 ⁷/₁₆" (H) × 7 ⁹/₁₆" (D)
275.6 × 137.7 × 179.2 mm

Weight: 3.3 lbs (1.5 kg)

Weight and dimensions shown are approximate.
Specifications are subject to change without notice.

Panasonic

PANASONIC BROADCAST & DIGITAL SYSTEMS COMPANY
DIVISION OF MATSUSHITA ELECTRIC CORPORATION OF AMERICA

Executive Office:

3330 Cahuenga Blvd W., Los Angeles, CA 90068 (323) 436-3500

EASTERN ZONE

One Panasonic Way 4E-7, Secaucus, NJ 07094 (201)348-7621

Mid-Atlantic/New England:

One Panasonic Way 4E-7, Secaucus, NJ 07094 (201) 348-7621

Southeast Region:

1225 Northbrook Parkway, Ste 1-160, Suwanee, GA 30024 (770) 338-6835

Central Region:

1707 N Randall Road E1-C-1, Elgin, IL 60123 (847) 468-5200

WESTERN ZONE:

3330 Cahuenga Blvd W., Los Angeles, CA 90068 (323) 436-3500

Dallas Region:

6226 Abington Way, Houston, TX 77008 (713) 802-2726

No. CA/Northwest Region:

5870 Stoneridge, #3, Pleasanton, CA 94588 (925) 416-5108

Government Marketing Department:

52 West Gude Drive, Rockville, MD 20850 (301) 738-3840

Panasonic Canada Inc.

5770 Ambler Drive, Mississauga, Ontario L4W 2T3 (905) 624-5010

Panasonic Sales Company

Division of Matsushita Electric of Puerto Rico Inc.

San Gabriel Industrial Park, 65th Infantry Ave., Km. 9.5, Carolina, Puerto Rico 00630 (787) 750-4300